

Power Jacks

POWER JACKS LTD.
 "SYM-METRIC"
 RANGE OF CUBIC METRIC ACTUATORS
 DESIGNED AND MANUFACTURED IN THE UK
 200 KN RATED CAPACITY
 ANTI-BACKLASH WITH INVERTED TRANSLATING SCREW
 65mm DIA. X 12mm PITCH MACHINE SCREW

ST200-****-E1RV-CPC100B (THREADED END)
 ST200-****-T1RV-CPC100B (TOP PLATE)
 ST200-****-C1RV-CPC100B (CLEVIS END)

**** = RAISE IN MM
 REFER TO PRODUCT CODE FOR VARIANT SPECIFICATION.

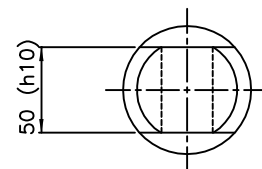
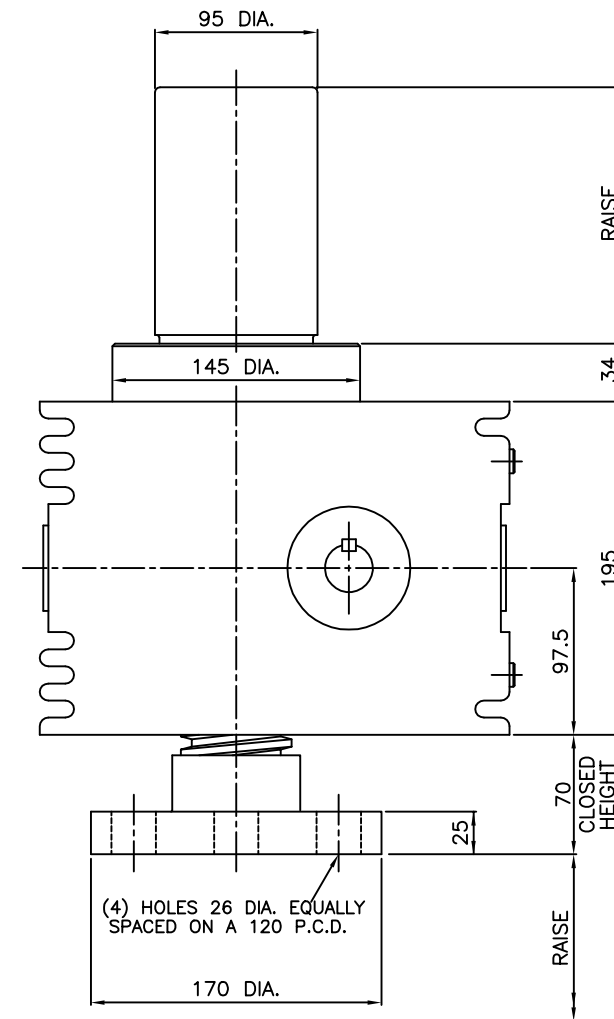
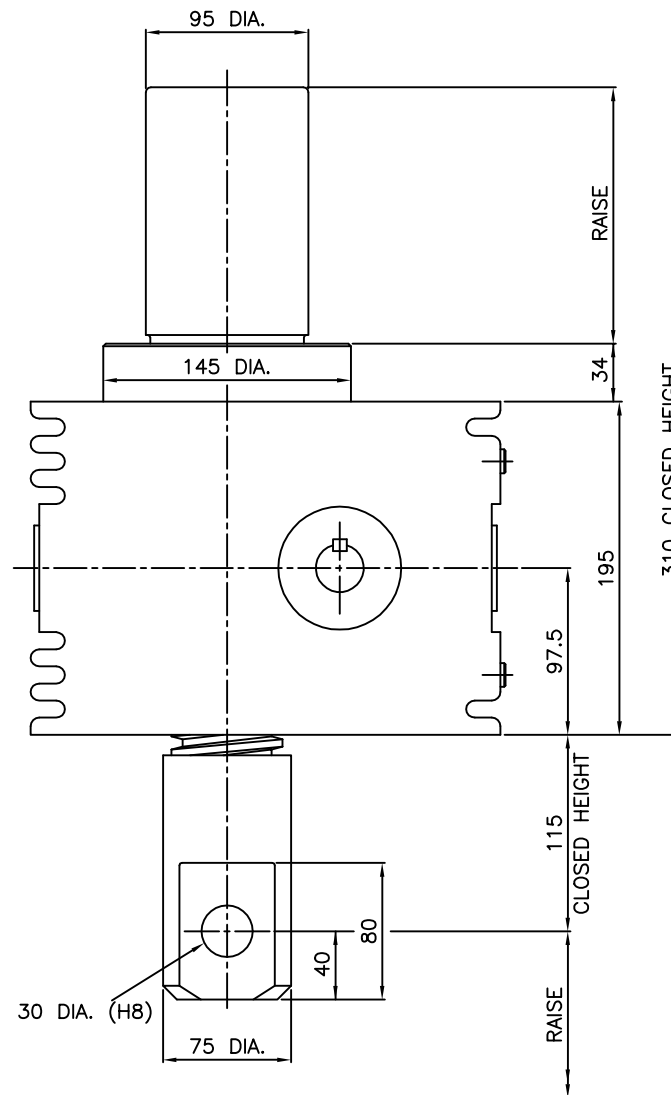
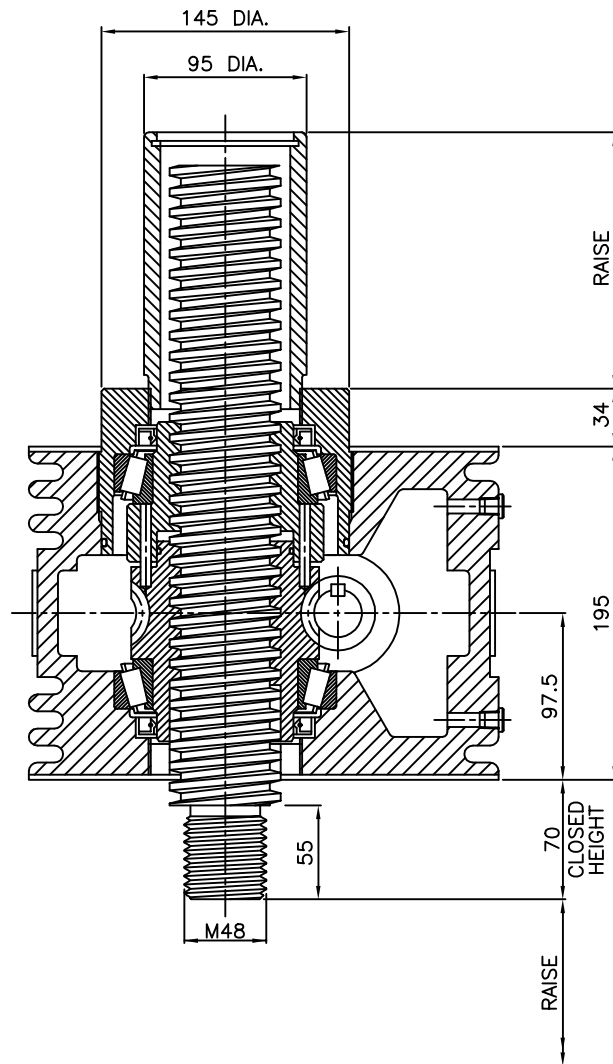
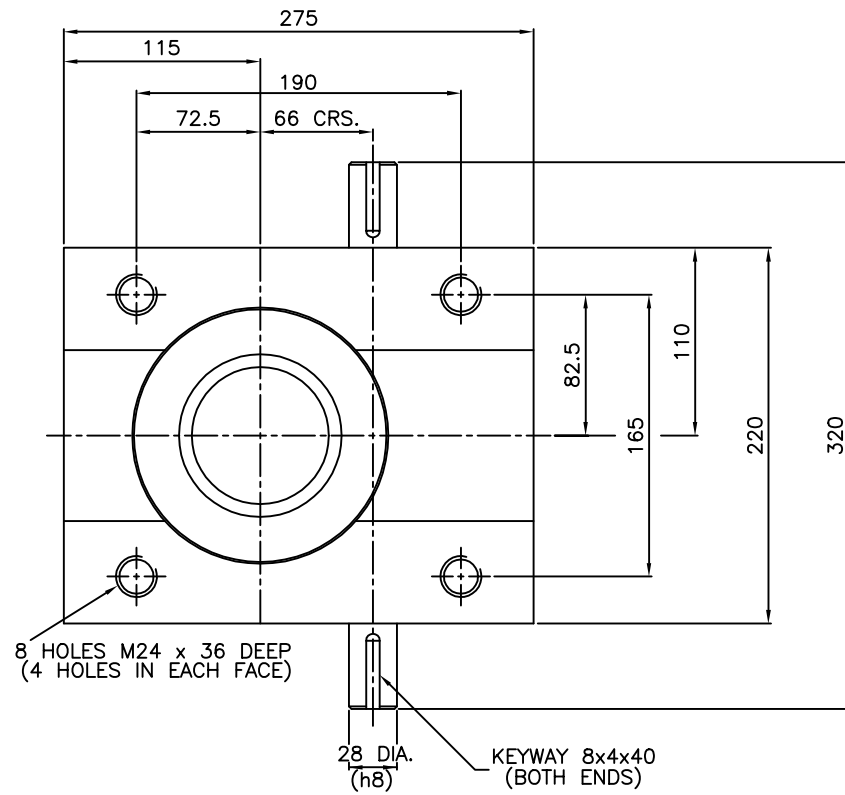

IF TOP PLATES OR CLEVIS ENDS ARE NOT ALREADY FITTED, IT WILL BE NECESSARY TO DRILL-DIMPLE LIFTING SCREW THREADING TO ACCOMMODATE CUP-POINTS OF LOCKING-SCREWS.
 NOTE - DIMPLE TO FULL DIAMETER OF DRILL TO 1mm-1.5mm BELOW ROOT DIA. OF THREAD.